

ACTIVE DIAGNOSTICS OF TOROIDAL BEARINGS USING ACOUSTIC EMISSION TECHNIQUE

Housam Mohammad, Ing.

ÚSTAV KONSTRUOVÁNÍ
Fakulta strojního inženýrství
VUT v Brně

Brno, 22. 6. 2020



CONTENTS

- Motivation to solve the problem
- Overview of Current state of knowledge
- The objectives of the dissertation
- Scientific questions and working hypotheses
- Solution methods
- Expected schedule
- Cooperation with other institutions

Motivation

Introduction

Toroidal bearings are characterized by their special design, which combines the **self-aligning** capability with the **axial displacement** ability, and that makes their applications versatile and valuable.

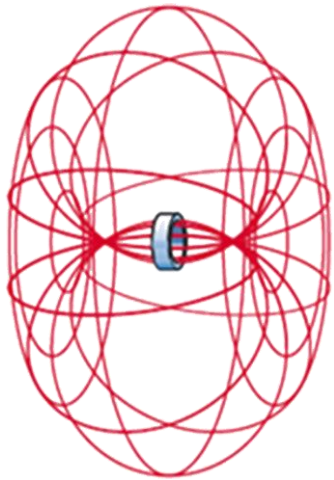

The inner and outer raceways are parts of a **torus**

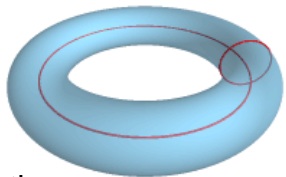

Torus equation

$$\left(R - \sqrt{x^2 + y^2}\right)^2 + y^2 = r^2$$

en.wikipedia.org/wiki/Torus



www.skf.com

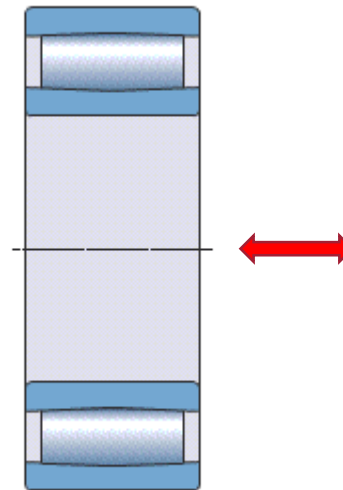

Ability to adapt to axial misalignment

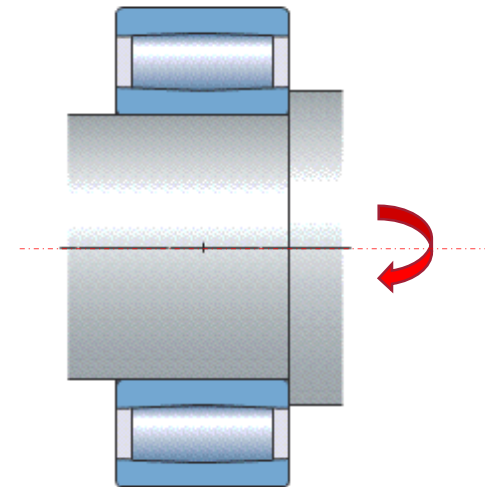

Ability to adapt to angular misalignment

Motivation

- Toroidal Bearings are **newly produced** type of bearings.
 - First invented and produced by SKF in mid 90s (CARB).
 - After 2005, other companies started production, mainly Schaeffler (TORB).
 - In the Czech Republic, by ZKL, just 2 years ago. And there is a pressing need to further study their characteristics and to improve their quality, competitiveness, and viability.
- There is No research in the current scientific literature on toroidal bearings.
- Toroidal bearings are relatively expensive. They should always be tested by Non-Destructive Method. And **Acoustic Emission** is a well developed NDT technique which has been proven through many studies to be effective for predicting RCF in early stages. While at the same time this technique is still in constant development with regard to the sensitivity, the parameters, and the signal processing techniques.
- Testing and understanding toroidal bearings and its wide range of applications gives better understanding of other types of bearings which have the same characteristics.

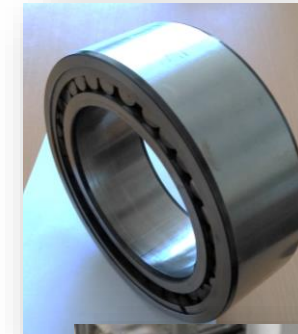

www.zkl.cz



www.schaeffler.com

Current of Stat of Knowledge

Blank (white) spots in the Current State of Knowledge :

The subject of testing the toroidal bearing using AE with regard to its ability to tolerate angular and axial misalignment was not studied before.

Active Diagnostics Of Toroidal Bearings Using AE Technique

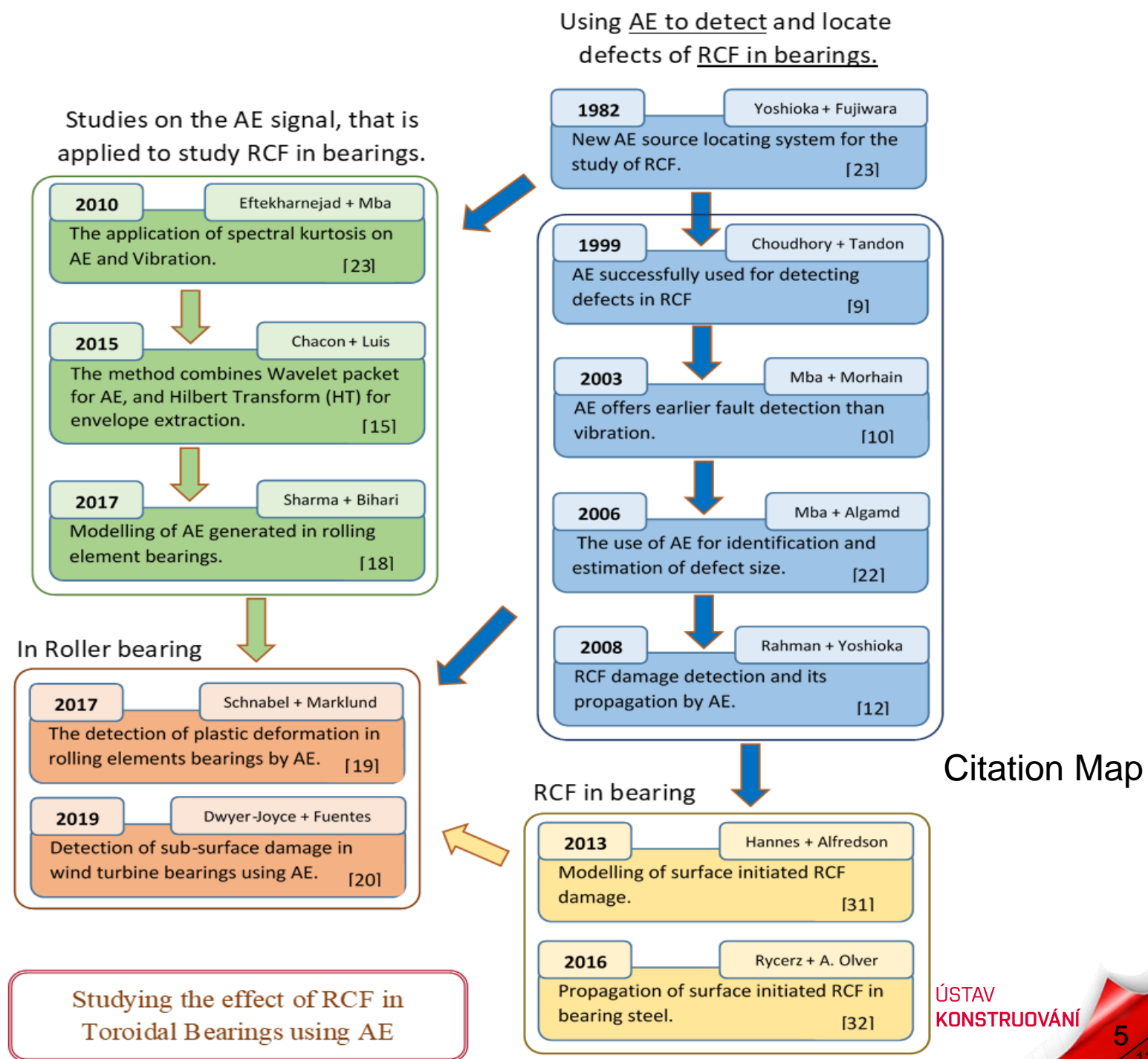

The Objectives Of The Dissertation

- ❑ The main objective is to study the detection of **Rolling Contact Fatigue (RCF) damage in Toroidal Bearings** using **Acoustic Emission**, and to provide a deeper explanation of the origin the RCF damage in these bearings. Using AE to detect RCF damage in bearings has been proven as a viable technique for predicting and detecting RCF.
- ❑ Special attention will be paid to studying the ability to accommodate **angular and axial misalignment** in toroidal bearings, theoretically and experimentally.
- ❑ Studying the application of Toroidal Bearings in **wind turbines**.
- ❑ Designing and constructing a special **test rig for bearings** that allows angular and axial misalignments. This test rig would be able to test all types of self-aligning bearings.
- ❑ Along with the experiments a **theoretical study** will be carried out to support the experimental results, and to explain any contradictions. The theoretical study depends on modelling the toroidal bearing using a finite element analysis software. This model will be developed with collaboration with the R&D of the producer of the tested toroidal bearings.

Assumed outcomes along the dissertation

- At least one impact article
- At least two publications in conference proceedings
- Recognition of novelty for a new testing device

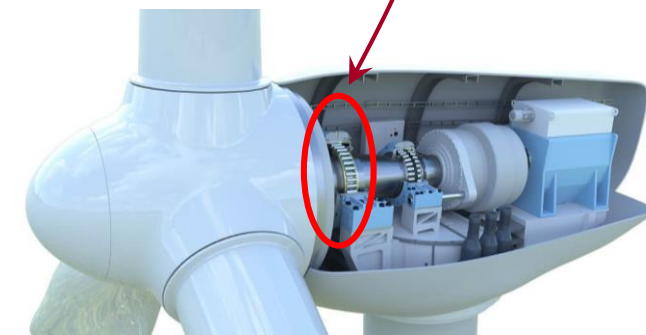

Scientific Questions And Hypotheses

Q1. How does the ability to tolerate angular and axial misalignments in toroidal bearings affect their performance and their life expectancy? And how such effect can be specified or even measured?

H1. The ability to tolerate misalignment should have a noticeable impact on the RCF and other characteristics of the bearing. Some experienced sources even predict that the effect should be positive with regard to the bearing life and performance, since there is a wider (extended) contact surface between the rollers and the races.

A comparison study of the AE signals for the same (or identical) sample bearings in different angular and axial positions should specify such impact, and further analysis of the signal could even measure that impact.

Scientific Questions And Hypotheses

Q2. How does the shape of toroidal rolling element affect the operation parameters of the bearing (noise, vibration, temperature...)?

H2. The change in roller shape will influence the operating parameters firstly because of the change of the length of the **contact line** the raceways, which will affect the RCF characteristics of the bearing. Secondly because it will directly affect the **operating internal clearance** of the bearing, and the operating internal clearance influences the load distribution in a bearing, which ultimately affects its operation parameters, such as noise, vibration, and temperature.

In addition, it can influence whether the rolling elements move by **rolling or sliding** motion.

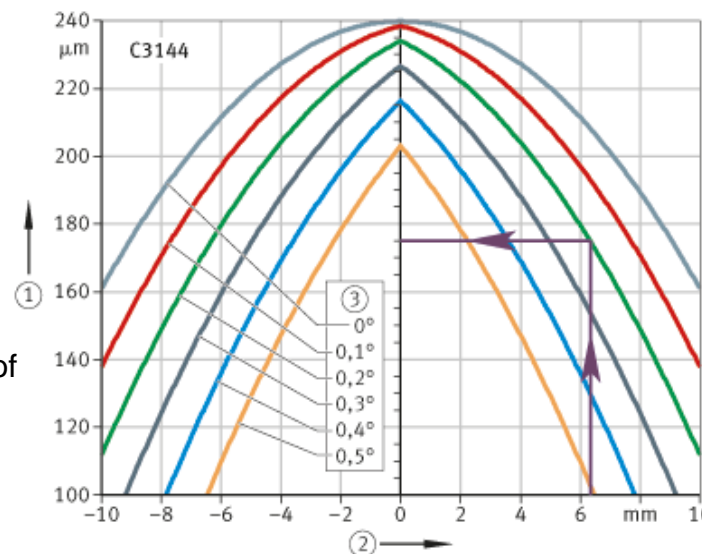
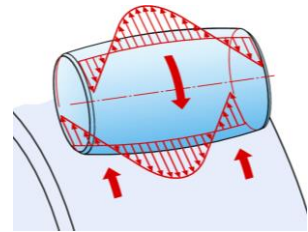

The resulting operating clearance of the Toroidal bearing (TORB C3144) as a function of angular and axial misalignments. Where:

1. **Operating clearance** in μm
2. Axial misalignment in mm
3. angular misalignment in $^\circ$. [8]

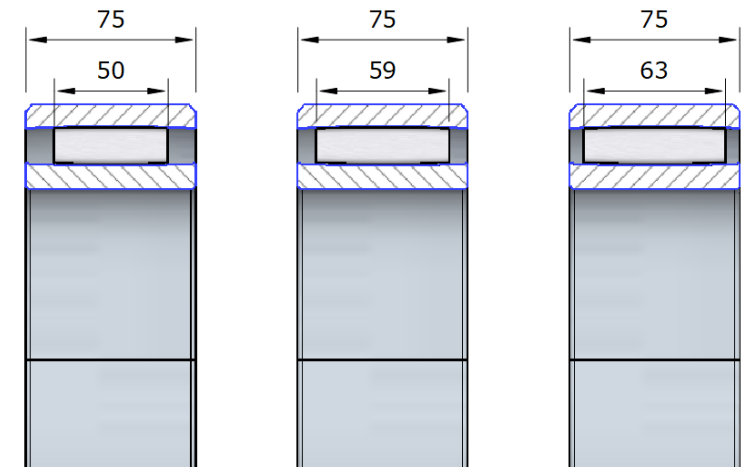

Scientific Questions And Hypotheses

Q3. What are the operating parameters that influence the initiation of RCF cracks in bearing? And how can that be reflected when studying RCF initiation in toroidal bearings?

H3. P. Rycerz et al. [32] concluded that **contact pressure** was shown to be one of the main parameters controlling the propagation rate of surface initiated RCF cracks in bearing steel. And since the **contact line** (toroidal contour) between the rollers and the raceways in toroidal bearings is bigger (longer) than the contact line in other types of bearings, this mean a smaller contact pressure between the inner and outer rings and the rollers, when applying the same loading under the same conditions.

But this hypothesis cannot be taken into consideration without a much deeper analysis and an experimental proof because of the complex relationships between the toroidal bearing geometry properties and the operating parameters.

Solution Methods

- It will be necessary to perform different experimental measurements in more than one laboratory.
- The experiment setup in the laboratories of ZKL (the producer of the toroidal bearing) tests the material of the bearing.
- The experiment setup in UK laboratories will focus on the effect of misalignment on the bearing.
- AE will be used in both experiments as the tool to detect the damage caused by RCF.
- The theoretical model that will be developed alongside the experiments.

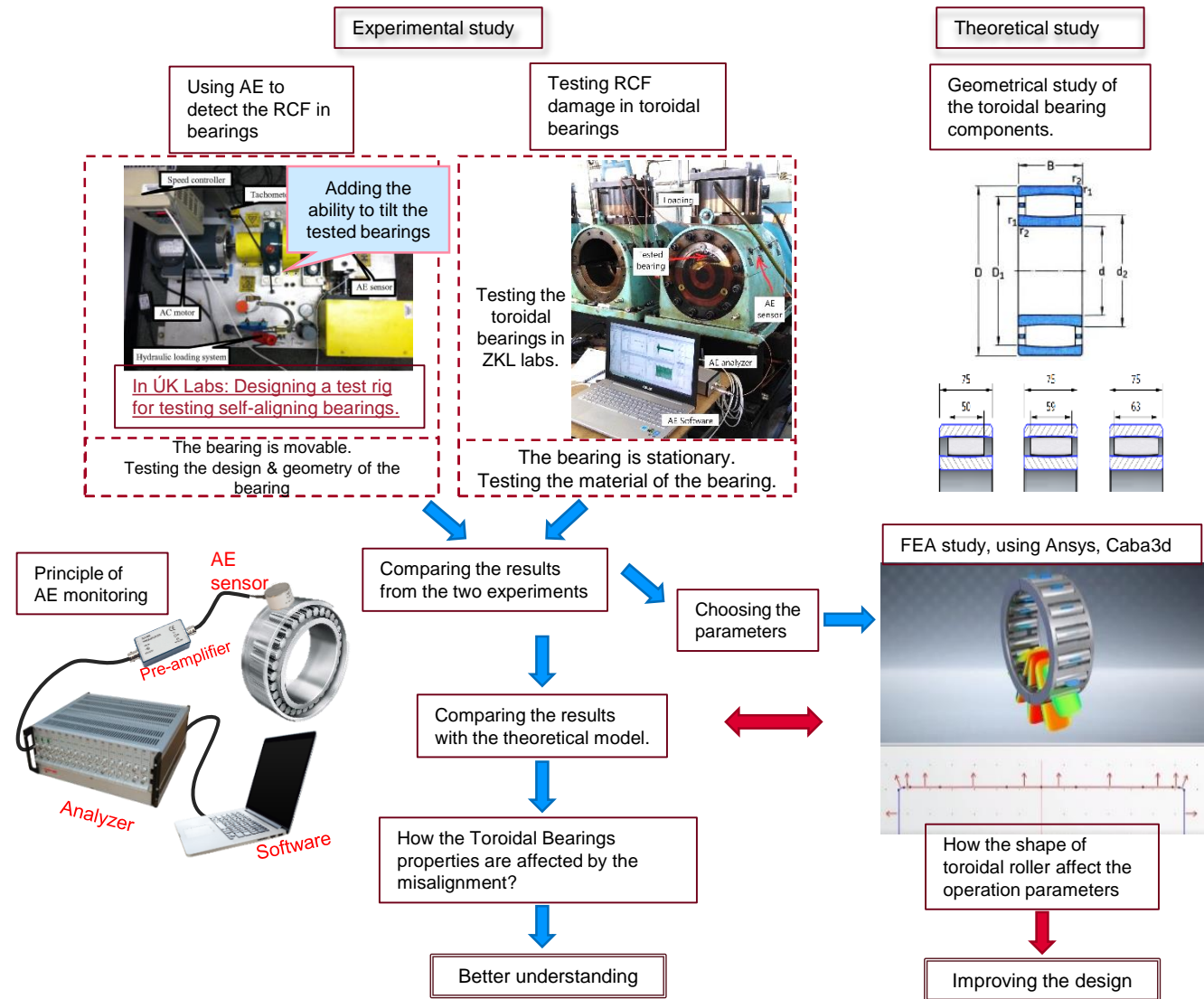

Expected Schedule

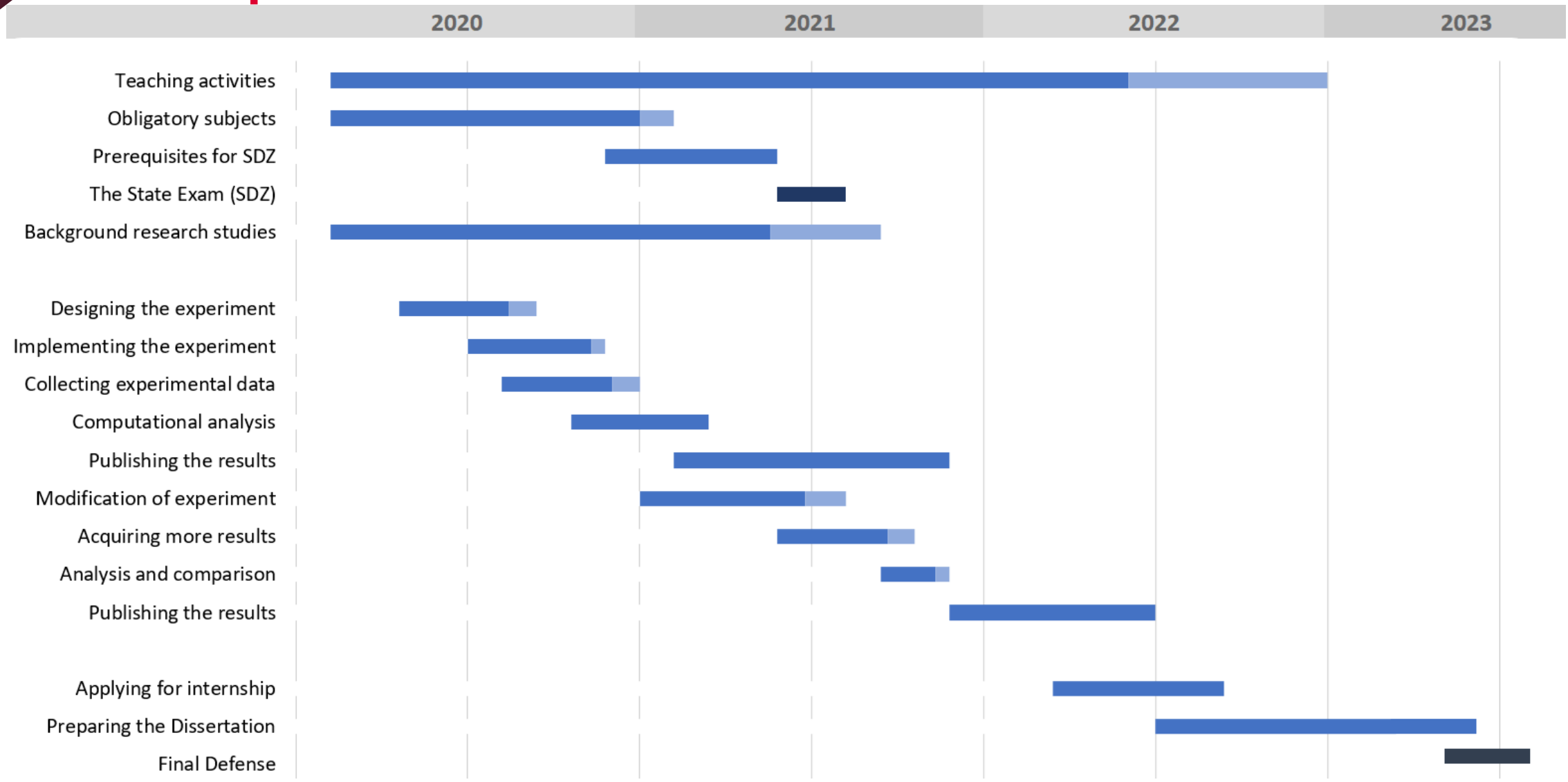

Cooperation With Other Institutions

The R&D department in the Czech Bearing Company (ZKL).



Technology Agency of the Czech Republic (TAČR).



The Czech Society of Non-destructive testing (ČNDT).



The Czech private AE producer of AE systems - DAKEL



Thank you for your attention

Housam Mohammad, Ing.

215325@vutbr.cz



**ÚSTAV
KONSTRUOVÁNÍ**

www.ustavkonstruovani.cz